



SIAT

M. J. MAILLIS GROUP

SR4 / SR46

Semi Automatic Carton Sealers



Descent limiting device

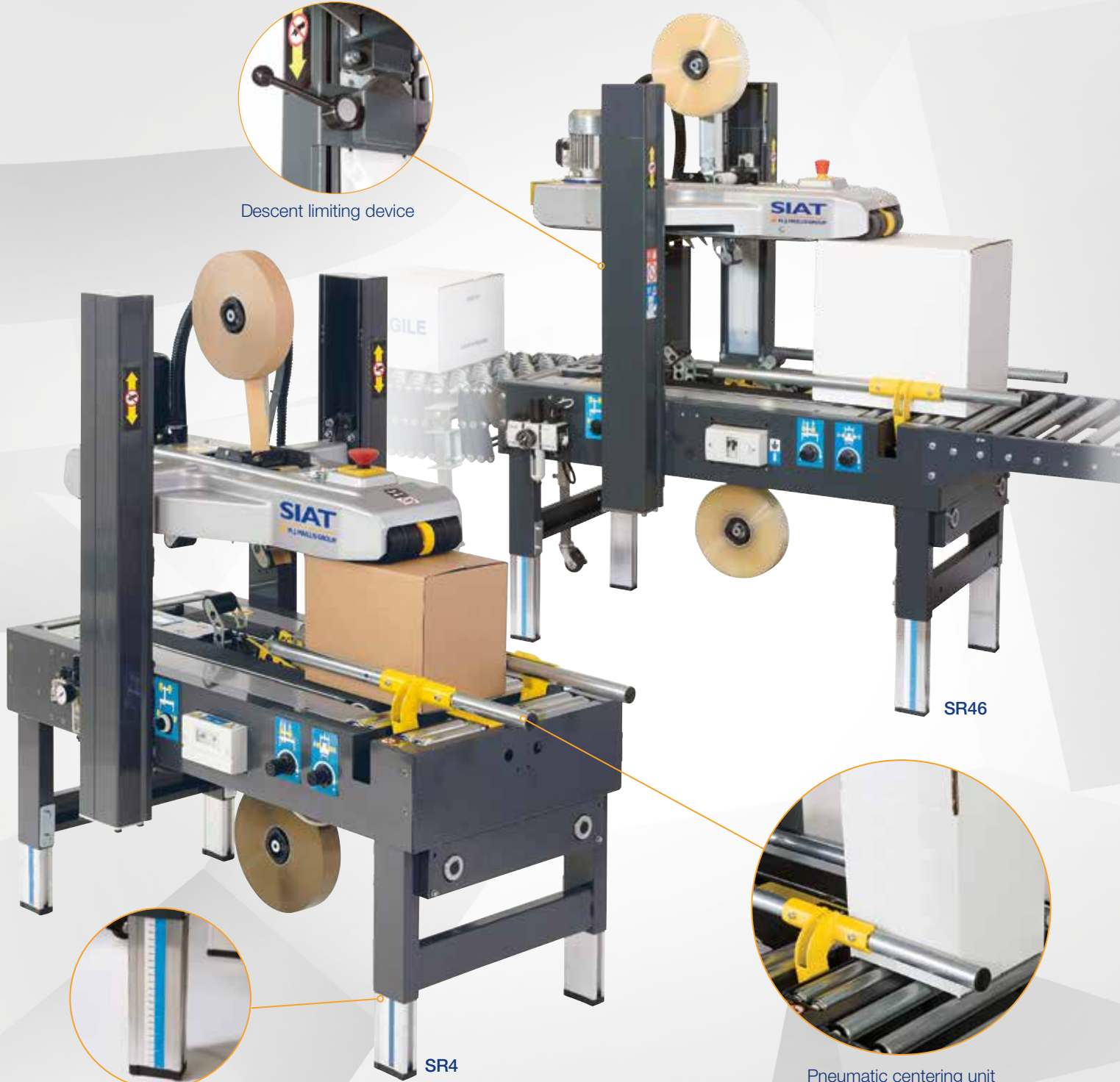

SR46

SR4



Aluminium telescopic legs



Pneumatic centering unit



for more details:



SR4

Semi-automatic random size carton machine, designed to respect the **CE standards** of semi-automatic machine.

Structure: in metal painted with epossidic paint and columns in aluminum, sliding plan of the boxes with galvanized rolls and stainless steel plate.

Working Cycle: the operator folds the top folders and pushes the box in the machine, that adjusts itself according to the box size and proceeds to the top and bottom sealing simultaneously.

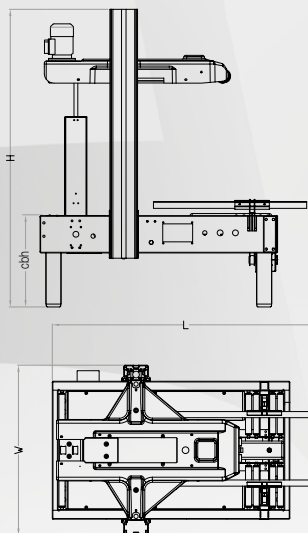

other languages: www.siat.com



> **Machine dimensions**

Dimensioni macchina
Machinemessungen
Dimensions machine
Dimensiones de la máquina

Size / Weigth packaging			LxWxH
> SR4	145	185	130x78x115
> SR46	180	225	135x105x155

> **SR4**

	Min.	Max
L	1395	-
W	740	-
H	1180	1520
cbh	480	800
AS 77	580	900
AS 80	700	1100

> **SR46**

	Min.	Max
L	1395	-
W	890	-
H	1560	1900
cbh	480	800
AS 77	580	900
AS 80	700	1100

> **Taping units**

Unità nastranti
Verschliesseinheiten
Unité enrubanneuse
Unidades de precinto

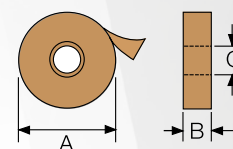

> **Box dimensions**

Dimensioni delle scatole
Kartonabmessungen
Dimensions des boîtes
Dimensiones de las cajas

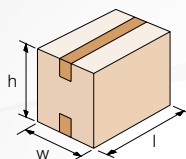

> **SR4**

	K11R std. / K12R on demand	
	Min.	Max
l	150	∞
w	140 / 170	500
h	100	500

> **SR46**

	K12R	
	Min.	Max
l	150	∞
w	170	650
h	100	650

	K11R/ K12R
	mm
A	410 Max
B	50 / 75
C	76

> **Production capacity**

Capacità di produzione
Produktionskapazität
Capacité de production
Capacidad de producción

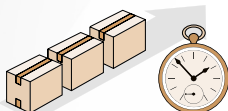

> SR4	Bph
Max pcs.*	900

> SR46	Bph
Max pcs.*	900

* Always based on shorter manageable box

> **Air consumption**

Consumo aria
Druckluftverbrauch
Consommation air comprimé
Consumo de arie

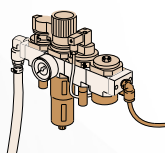

> SR4	NI.
Cycle	9

> SR46	NI.
Cycle	9

from 5,5 bar to 7 bar

> **Standard voltage**

Voltaggio standard
Standardspannung
Tension standard
Voltaje estándar

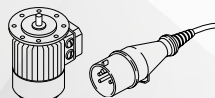

> SR4	
	380/400V - 50Hz - 3F
	440V - 60Hz - 3F
Amps	1,08
Power kW	0,26
Phase	3Ph + N + PE

> SR46	
	380/400V - 50Hz - 3F
	440V - 60Hz - 3F
Amps	1,08
Power kW	0,26
Phase	3Ph + N + PE

> **Optionals**

Accessori
Zübehör
Accessories
Accesorios

> **AS80**
Higer legs
Set gambe più alte
Höhere Stützen
Pieds plus hauts
Set patas mas altas



> **AS77**
Casters
Set ruote
Satz Umlaufräder
Roues
Set ruedas

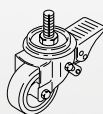

> **RG**
Roller conveyor
Piani a rulli Idler
Rollenbahnen
Plans à rouleaux
Tramo de rodillos

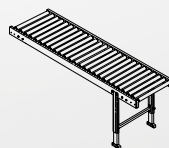

> **GTL - GTR**
Extendable conveyor
Rulliera estensibile
Ausziehbare rollenbahnen
Convoyeur extensible
Rodillos extensibles

